



Cu-connections

Elpress Cu-connections are produced from electrolytic 99.9% copper. Terminals and through connectors exist in a large variety of types for stranded as well as for flexible conductors. C-sleeves for earth conductor branch off also come in a large number of sizes. If a standard type is not suitable, we produce tailor made designs specific to the application.

KR/KRF terminals and KS/KSF connectors may be used for both stranded and flexible conductors.

KRD terminals and KSD connectors are used for stranded conductors.

KRT terminals and KST connectors equal the German "Standard types" (not DIN!) and are used for stranded conductors.

C-sleeves are used for branch-off or cross connections for mainly earth conductors such as for lightning protection and earthing grids.

By crimping Elpress terminals and connectors with Elpress crimp tools, connections are achieved that meet the requirements of SEN 245010, BS 4579:1, VDE 0220:1, EN-IEC 61238:1 whichever is applicable.

Number of crimps

Normally only one crimp per conductor end is needed up to and including 150 mm² and two crimps for larger areas. For detailed information see crimp die tables in Chapter 10. If possible multiple crimps should be positioned with a few mm distance from each other and from the neck end. In many cases however, overlapping crimps have to be made for space reasons.

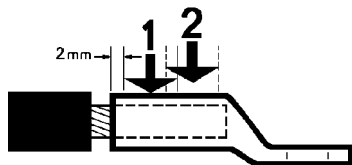

Crimp sequence with two adjacent crimps.

Markings on Cu-connections

Elpress marking system for Cu-connectors shows logotype, conductor area and id-number for crimp die to be used. This system enables final inspection of proper die use as the die number is automatically imprinted by the die on the crimped barrel.



Marking of tube terminals	
32 (on the terminal neck)	
ID-no. for the hexagonal die	
(Elpress logo) 300-16F (on the palm)	
300 = Cu-conductor area, mm ²	
16 = hole for screw M16	
F = KRF	



Marking of connectors	
(Elpress logo) 27	
ID-no. for hexagonal die	
185 F (possible screen area and an earth-sign)	
185 = Cu-conductor area, mm ²	
F = KSF	



Marking of tap-off C-sleeves	
120 - 150/70 - 95	
120 - 150 = Cu-wire range, mm ²	
70 - 95 = Cu-wire range, mm ²	
(Elpress logotype) C16 - 13 Cat.no.	

Stud holes in terminal palms

Screw-dimension	Hole diameter tol. H13 (Ø mm)
M 3	3,2
M 4	4,3
M 5	5,3
M 6	6,4
M 8	8,4
M 10	10,5
M 12	13
M 16	17
M 20	21
M 24	25



EasyGuide

-to easily introduce flexible conductors into the terminal

EasyGuide consists of a stand (EG-TS) and tapered inserts (EG-xx) which are chosen to fit the terminal size. Place the terminal in the guiding groove on one side of the insert and introduce the conductor from the other side, open the insert halves and remove the terminal with the conductor in place.

Finally a simple way to get all the strands into the barrel! Suits Elpress type - KRF terminals and connectors from 6 to 240 mm².

Inserts	
6 mm ²	EG 6
10 mm ²	EG 10
16 mm ²	EG 16
25 mm ²	EG 25
35 mm ²	EG 35
50 mm ²	EG 50
70 mm ²	EG 70
95 mm ²	EG 95
120 mm ²	EG 120
150 mm ²	EG 150
185 mm ²	EG 185
240 mm ²	EG 240



EasyGuide.



Tube terminals 0,75 - 10 mm², KR

■ Data: electrolytic copper, tin plated, cable inspection hole, for flexible and stranded, Cu-conductors.

Marking example KR: 10 10 (Elpress logotype included)

10 = mm²

10 = palm hole for M10



4

Cat. no. mm ² - bolt hole M	mm W	d	N	N ₁	L	Pcs/ pack	Crimp tools page
KR 0,75-3*	6,0	1,3	3,2	3,8	16,0	100	8:9, 8:18-20
KR0,75-4*	6,0	1,3	3,2	3,8	16,0	100	
KR 1,5-3*	6,5	1,8	3,4	3,6	16,0	100	
KR 1,5-4*	6,5	1,8	4,2	4,3	17,0	100	
KR 1,5-5*	7,5	1,8	4,8	4,7	18,0	100	
KR 2,5-3*	7,5	2,3	3,5	4,1	17,0	100	
KR 2,5-4*	7,5	2,3	4,2	4,1	18,0	100	
KR 2,5-5*	8,5	2,3	4,8	4,8	19,0	100	
KR 2,5-6*	8,5	2,3	5,1	4,9	19,0	100	
KR 4-4	8,5	3,0	4,2	5,8	21	100	8:11 9:3
KR 4-5	9,0	3,0	4,8	5,2	22	100	
KR 4-6	10,0	3,0	5,0	7,0	23	100	
KR 6-4	9,5	4,0	4,0	7,0	22	100	
KR 6-5	9,5	4,0	5,0	6,0	22	100	
KR 6-6	10,0	4,0	5,5	6,5	23	100	
KR 6-8	13,5	4,0	7,0	10,0	30	100	
KR 10-5	11,5	5,0	6,0	7,0	29	100	9:4-30
KR 10-6	11,5	5,0	6,0	7,0	29	100	
KR 10-8	13,5	5,0	7,0	9,0	33	100	
KR10-10	16,0	5,0	8,0	10,0	34	100	
KR10-12	19,0	5,0	10,0	14,0	41	100	

* no inspection hole



Tube terminals 16 - 800 mm², KRF

■ Data: electrolytic copper, tin plated, cable inspection hole, for flexible and stranded, Cu-conductors.

Marking example KRF: 70 10F, KR D: 500 16 (Elpress logotype included)

70 = mm² 10 = palm hole for M10 F = type KRF, for stranded and flexible conductors
 500 = mm² 16 = palm hole for M16

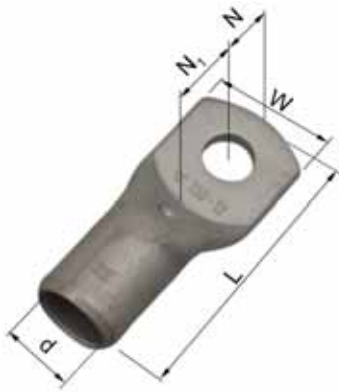

Cat. no. mm ² - bolt hole M	mm W	d	N	N ₁	L	Pcs/ pack	Die no.	Crimp tools page	
KRF 16-6	13,0	6,0	8,0	9,0	34	100	9	9:3-6	9:8-30
KRF 16-8	13,0	6,0	8,0	9,0	34	100	9		
KRF 16-10	16,0	6,0	10,0	11,0	38	100	9		
KRF 16-12	22	6,0	12,0	13,0	47	100	9		
KRF 25-6	16,0	8,0	8,0	10,0	39	100	11		
KRF 25-8	16,0	8,0	8,0	10,0	39	100	11		
KRF 25-10	17,0	8,0	10,0	11,0	42	100	11		
KRF 25-12	22	8,0	12,0	13,0	47	100	11		
KRF 35-6	18,0	9,0	10,0	11,0	47	100	13		
KRF 35-8	18,0	9,0	10,0	11,0	47	100	13		
KRF 35-10	18,0	9,0	10,0	11,0	47	100	13		
KRF 35-12	22	9,0	12,0	14,0	52	100	13		
KRF 50-6	21	11,0	11,0	12,0	50	100	14,5		
KRF 50-8	21	11,0	11,0	12,0	50	100	14,5		
KRF 50-10	21	11,0	11,0	12,0	50	100	14,5		
KRF 50-12	21	11,0	12,0	14,0	53	100	14,5		
KRF 50-16	27	11,0	15,0	17,0	59	100	14,5		
KRF 70-6	25	13,0	11,0	12,0	55	50	17		
KRF 70-8	25	13,0	11,0	12,0	55	50	17		
KRF 70-10	25	13,0	11,0	12,0	55	50	17		
KRF 70-12	25	13,0	12,0	14,0	58	50	17		
KRF 70-16	28	13,0	15,0	17,0	64	50	17		
KRF 95-8	29	15,0	15,0	17,0	69	50	20		
KRF 95-10	29	15,0	15,0	17,0	69	50	20		
KRF 95-12	29	15,0	15,0	17,0	69	50	20		
KRF 95-16	29	15,0	15,0	17,0	69	50	20		
KRF 120-10	32	17,0	15,0	17,0	73	25	22		
KRF 120-12	32	17,0	15,0	17,0	73	25	22		
KRF 120-16	32	17,0	15,0	17,0	73	25	22		
KRF 150-10	36	19,0	15,0	17,0	80	25	25		
KRF 150-12	36	19,0	15,0	17,0	80	25	25		
KRF 150-16	36	19,0	15,0	17,0	80	25	25		
KRF 150-20	36	19,0	19,0	20	87	25	25		
KRF 185-10	39	21	15,0	17,0	86	20	27		
KRF 185-12	39	21	15,0	17,0	86	20	27		
KRF 185-16	39	21	15,0	17,0	86	20	27		
KRF 185-20	39	21	19,0	20	93	20	27		
KRF 240A-10	42	22,5	19	20	96	10	30	9:13-30	
KRF 240A-12	42	22,5	19	20	96	10	30		
KRF 240A-16	42	22,5	19	20	96	10	30		
KRF 240A-20	42	22,5	19	20	96	10	30		
KRF 300A-10	45	24,5	22	32	116	10	32		
KRF 300A-12	45	24,5	22	32	116	10	32		
KRF 300A-16	45	24,5	22	32	116	10	32		
KRF 300A-20	45	24,5	22	32	116	10	32		
KRF 300A-24	45	24,5	22	32	116	10	32		

* no inspection hole
 ** total palm length





Cat. no. mm ² - bolt hole M	mm W	d	N	N ₁	L	Pcs/ pack	Die no.	Crimp tools page
KRF 400A-00	56	30	-	-	125	10	38	9:13-15 9:23-30 ↓
KRF 400A-12	56	30	22	33	125	10	38	
KRF 400A-16	56	30	22	33	125	10	38	
KRF 400A-20	56	30	22	33	125	10	38	
KRF 400A-24	56	30	22	33	125	10	38	
For flexible Cu-conductors								
KRF 500-00	61	33	70**		160	5	42	9:35-36 ↓
KRF 500-16	61	33	25	35	150	5	42	
KRF 500-20	61	33	25	35	150	5	42	
KRF 500-24	61	33	25	35	150	5	42	
KRF 630-00	75	39	80**		195	1	53	9:23-25
KRF 630-20	75	39	35	45	195	1	53	
KRF 630-24	75	39	35	45	195	1	53	
KRF 800-00	75	42	80**		195	1	53	
KRF 800-24	75	42	35	45	195	1	53	
For stranded Cu-conductors								
KRD 500-00	58	31	70**		160	5	40	9:23-30 ↓
KRD 500-16	58	31	25	35	150	5	40	
KRD 500-20	58	31	25	35	150	5	40	
KRD 500-24	58	31	25	35	150	5	40	
KRD 630-00	65	34	75**		165	1	45	9:23-25
KRD 630-20	65	34	25	35	150	1	45	
KRD 630-24	65	34	25	35	150	1	45	
KRD 800-00	75	39	80**		195	1	53	
KRD 800-24	75	39	35	45	195	1	53	
KRD 1000-00	80	43	80**		195	1	56	

* no inspection hole
** total palm length



Tube terminals 10 - 1000 mm², KRT

■ Data: electrolytic copper, tin plated, cable inspection hole, for stranded and round, compressed Cu-conductors.

Marking example KRT: 70 10 (Elpress logotype included)

70 = mm²

10 = palm hole for M10

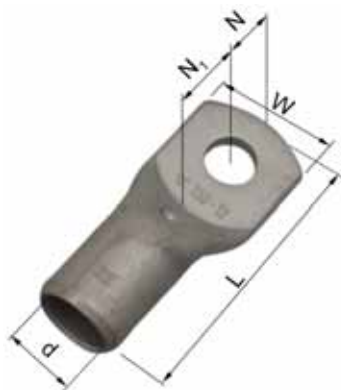

Cat. no.	mm W	d	N	N ₁	L	Pcs/ pack	Die no.	Crimp tools page	
KRT 10-5	10	4,5	6	8	29	100	7	9:3-9:6	9:8-30
KRT 10-6	10	4,5	6	8	29	100	7		
KRT 10-8	13	4,5	8	11	34	100	7		
KRT 10-10	16	4,5	8	11	34	100	7		
KRT 10-12	19	4,5	10	14	41	100	7		
KRT 16-5	12	5,5	6	8	34	100	8,5		
KRT 16-6	12	5,5	6	8	34	100	8,5		
KRT 16-8	15	5,5	8	11	39	100	8,5		
KRT 16-10	16	5,5	8	11	39	100	8,5		
KRT 16-12	19	5,5	10	15	47	100	8,5		
KRT 25-6	14	7	9	12	43	100	10		
KRT 25-8	15	7	9	12	43	100	10		
KRT 25-10	16	7	9	12	43	100	10		
KRT 25-12	19	7	12	13	48	100	10		
KRT 35-6	17	8,5	9,5	11,5	49	100	12		
KRT 35-8	17	8,5	9,5	11,5	49	100	12		
KRT 35-10	19	8,5	9,5	11,5	49	100	12		
KRT 35-12	22	8,5	12	14	53	100	12		
KRT 50-6	20	10	11	12	53	100	14		
KRT 50-8	20	10	11	12	53	100	14		
KRT 50-10	20	10	11	12	53	100	14		
KRT 50-12	22	10	12	14	56	100	14		
KRT 70-8	23	12	11	12	55	100	16		
KRT 70-10	23	12	11	12	55	100	16		
KRT 70-12	23	12	12	14	58	100	16		
KRT 95-8	26	13,5	11	12	60	100	18		
KRT 95-10	26	13,5	11	12	60	100	18		
KRT 95-12	26	13,5	12	14	63	100	18		
KRT 95-16	28	13,5	15	17	69	100	18		
KRT 120-10	28	15	11	14	64	100	19		
KRT 120-12	28	15	12	14	64	100	19		
KRT 120-16	28	15	15	17	70	100	19		
KRT 150-12	32	17	15	17	76	50	22		
KRT 150-16	32	17	15	17	76	50	22		
KRT 150-20	32	17	19	20	83	50	22		
KRT 185-12	35	19	15	17	79	50	24		
KRT 185-16	35	19	15	17	79	50	24		
KRT 185-20	35	19	19	20	86	50	24		
KRT 240-12	38	21	15	17	86	50	26		
KRT 240-16	38	21	15	17	86	50	26		
KRT 240-20	38	21	19	20	93	50	26		
KRT 300-12	44	24	19	20	100	25	30	9:13-30	
KRT 300-16	44	24	19	20	100	25	30		
KRT 300-20	44	24	19	20	100	25	30		
KRT 400-16	48	26	21	31	114	25	32		
KRT 400-20	48	26	21	31	114	25	32		
KRT 400-24	48	26	21	31	114	25	32		



Cu-terminals and connectors 0.75 - 1000 mm²

Cat. no.	mm W	d	N	N ₁	L	Pcs/ pack	Die no.	Crimp tools page
KRT 500-00	58	31	70**	-	160	-	40	9:23-36
KRT 500-16	58	31	25	35	150	-	40	↓
KRT 500-20	58	31	25	35	150	-	40	↓
KRT 500-24	58	31	25	35	150	-	40	↓
KRT 630-00	65	34	70**	-	160	-	45	9:23-25 9:35-36
KRT 630-20	65	34	25	35	150	-	45	↓
KRT 630-24	65	34	25	35	150	-	45	↓
KRT 800-00	75	39	80**	-	195	-	53	
KRT 800-24	75	39	35	45	195	-	53	
KRT 1000-00	80	43	80**	-	195	-	56	↓



Tube terminals 16 - 1000 mm², KRD

- Data: electrolytic copper, tin plated, cable inspection hole, for stranded and round, compressed Cu-conductors.

Marking example KRD: 70 10 (Elpress logotype included)

70 = mm²

10 = palm hole for M10



Cat. no.	mm W	d	N	N ₁	L	Pcs/pack	Die no.	Crimp tools page	
KRD 16-5	12	5,4	6	8	29	100	8	9:3-6	9:8-30
KRD 16-6	12	5,4	6	8	29	100	8		
KRD 16-8	14	5,4	8	9	33	100	8		
KRD 16-10	16	5,4	8	10	34	100	8		
KRD 16-12	18	5,4	10	14	41	100	8		
KRD 25-6	13	6,7	7	9	32	100	9		
KRD 25-8	13	6,7	7	9	32	100	9		
KRD 25-10	16	6,7	10	12	38	100	9		
KRD 25-12	22	6,7	12	13	47	100	9		
KRD 35-6	16	8	8	10	39	100	11		
KRD 35-8	16	8	8	10	39	100	11		
KRD 35-10	17	8	10	11	42	100	11		
KRD 35-12	22	8	12	13	47	100	11		
KRD 50-6	18	9,5	8,5	11,5	44	100	12		
KRD 50-8	18	9,5	8,5	11,5	44	100	12		
KRD 50-10	18	9,5	9,5	11,5	49	100	12		
KRD 50-12	20	9,5	12	14	53	100	12		
KRD 70-8	22	11,3	11	12	54	50	14		
KRD 70-10	22	11,3	11	12	54	50	14		
KRD 70-12	22	11,3	12	14	57	50	14		
KRD 95-8	24	13	11	12	58	50	16		
KRD 95-10	24	13	11	12	58	50	16		
KRD 95-12	24	13	12	14	61	50	16		
KRD 95-16	28	13	15	17	67	50	16		
KRD 120-10	28	15	11	15	64	50	19		
KRD 120-12	28	15	11	15	64	50	19		
KRD 120-16	28	15	15	17	70	50	19		
KRD 150-12	32	17	15	17	76	50	22		
KRD 150-16	32	17	15	17	76	50	22		
KRD 150-20	32	17	19	20	83	50	22		
KRD 185-12	36	19	15	17	80	50	25		
KRD 185-16	36	19	15	17	80	50	25		
KRD 185-20	36	19	19	20	87	50	25		
KRD 240-12	39	21	15	17	86	50	27		
KRD 240-16	39	21	15	17	86	50	27		
KRD 240-20	39	21	19	20	93	50	27		
KRD 300-12	44	24	19	20	100	25	30		
KRD 300-16	44	24	19	20	100	25	30		
KRD 300-20	44	24	19	20	100	25	30		
KRD 400-16	48	26	22	31	116	25	32		
KRD 400-20	48	26	22	31	116	25	32		
KRD 400-24	48	26	22	31	116	25	32		
KRD 500-00	58	31	70**		160	5	40		
KRD 500-16	58	31	25	35	150	5	40		
KRD 500-20	58	31	25	35	150	5	40		
KRD 500-24	58	31	25	35	150	5	40		
KRD 630-00	65	34	75**		165	1	45		
KRD 630-20	65	34	25	35	150	1	45		
KRD 630-24	65	34	25	35	150	1	45		
KRD 800-00	75	39	80**		195	1	53		
KRD 800-24	75	39	35	45	195	1	53		
KRD 1000-00	80	43	80**		195	1	56		

4





Tube terminals with two stud holes 70 - 400 mm², KRF

■ Data: electrolytic copper, tin plated, cable inspection hole, for flexible and stranded Cu-conductors.

Marking example KRF: 70 10F (Elpress logotype included)

70 = mm² 10 = palm hole for M10 F = type KRF, for flexible and stranded conductors

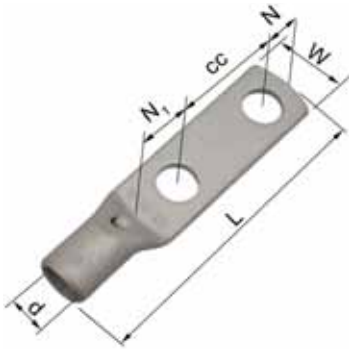

Cat. no. mm ² , bolt hole, cc-measure	mm W	d	N	N ₁	L	Pcs/ pack	Die no.	Crimp tools page	
KRF 70-12X2-40	25	13,0	12	18	103	25	17	9:3-4	9:5-14
KRF 95-12X2-40	29	15,0	12	18	109	25	20	↓	↓
KRF 120-12X2-40	32	17,0	12	19	113	25	22		↓
KRF 150-12X2-40	36	19,0	12	19	120	20	25		↓
KRF 185-12X2-40	39	21	12	20	126	20	27	9:13-30	
KRF 240A-12X2-40	42	22,5	12	21	130	10	30		↓
KRF 300A-12X2-40	45	24,5	12	22	136	10	32		↓
KRF 400A-12X2-40	56	30	12	23	145	10	38		↓

4

Tube terminals 45°, 10 - 150 mm², KRF

■ Data: electrolytic copper, tin plated, cable inspection hole, for flexible and stranded Cu-conductors.

Marking example KRF: 70 10F (Elpress logotype included)

70 = mm² 10 = palm hole for M10 F = type KRF, for stranded and flexible conductors

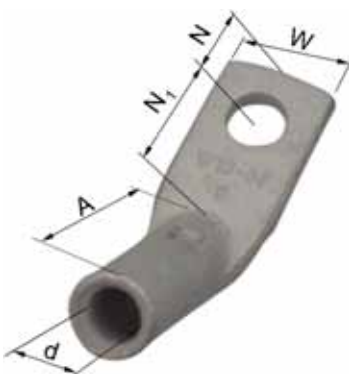

Cat. no. mm ² , Bolt, 45°	mm W	d	N	N ₁	A	Pcs/ pack	Die no.	Crimp tools page	
KR 10-6-45GR	13,0	5,0	6,5	11,5	19	100	8	9:3-6	9:8-30
KR 10-8-45GR	13,5	5,0	8,5	12,0	19	100	8		
KRF 16-6-45GR	13,0	6,0	6,5	11,5	23	100	9		
KRF 16-8-45GR	13,5	6,0	8,5	12,0	23	100	9		
KRF 25-6-45GR	17,0	8,0	6,5	11,5	24	100	11		
KRF 25-8-45GR	17,0	8,0	8,5	12,0	24	100	11		
KRF 25-10-45GR	17,0	8,0	11,5	13,5	24	100	11		
KRF 35-6-45GR	18,0	9,0	6,5	11,5	30	100	13		
KRF 35-8-45GR	18,0	9,0	8,5	12,0	30	100	13		
KRF 35-10-45GR	18,0	9,0	11,5	13,5	30	100	13		
KRF 50-8-45GR	21	11,0	8,5	17,5	31	100	14,5		
KRF 50-10-45GR	21	11,0	11,5	18,5	31	100	14,5		
KRF 50-12-45GR	21	11,0	12,5	19,5	31	100	14,5		
KRF 70-8-45GR	25	13,0	8,5	17,5	35	50	17		
KRF 70-10-45GR	25	13,0	11,5	18,5	35	50	17		
KRF 70-12-45GR	25	13,0	12,5	19,5	35	50	17		
KRF 95-10-45GR	29	15,0	11,5	18,5	40	50	20		
KRF 95-12-45GR	29	15,0	12,5	19,5	40	50	20		
KRF 95-16-45GR	29	15,0	15,5	20,5	40	50	20		
KRF 120-10-45GR	32	17,0	11,5	18,5	43	25	22		
KRF 120-12-45GR	32	17,0	12,5	19,5	43	25	22		
KRF 120-16-45GR	32	17,0	15,5	20,5	43	25	22	↓	
KRF 150-10-45GR	36	19,0	11,5	18,5	49	25	25		
KRF 150-12-45GR	36	19,0	12,5	19,5	49	25	25		
KRF 150-16-45GR	36	19,0	15,5	20,5	49	25	25		↓



Tube terminals 45°, 10 - 120 mm², KRT

- Data: electrolytic copper, tin plated, without cable inspection hole, for stranded, round, compressed Cu-conductors.

Marking example KRT: 70 10 (Elpress logotype included)

70 = mm²

10 = palm hole for M10

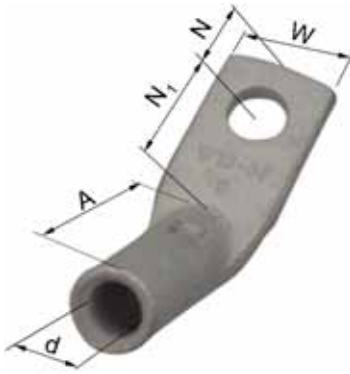

Cat. no.	mm W	d	N	N ₁	A	Pcs/pack	Die no.	Crimp tools page	
								9:3-6	9:8-30
KRT 10-6NS-45GR	13	4,5	6,5	11,5	20	100	7	↓	↓
KRT 10-8NS-45GR	13,5	4,5	8,5	12	20	100	7		
KRT 16-6NS-45GR	13	5,4	6,5	11,5	23	100	8,5		
KRT 16-8NS-45GR	13,5	5,4	8,5	12	23	100	8,5		
KRT 16-10NS-45GR	16	5,4	11,5	13,5	23	100	8,5		
KRT 25-6NS-45GR	14	7	6,5	11,5	26	100	10		
KRT 25-8NS-45GR	14	7	8,5	12	26	100	10		
KRT 25-10NS-45GR	16	7	11,5	13,5	26	100	10		
KRT 35-6NS-45GR	17	8,5	6,5	11,5	30	100	12		
KRT 35-8NS-45GR	17	8,5	8,5	12	30	100	12		
KRT 35-10NS-45GR	19	8,5	11,5	13,5	30	100	12		
KRT 50-8NS-45GR	20	10	8,5	17,5	32	100	14		
KRT 50-10NS-45GR	20	10	11,5	18,5	32	100	14		
KRT 50-12NS-45GR	22	10	12,5	19,5	32	100	14		
KRT 70-8NS-45GR	23	12	8,5	17,5	38	50	16		
KRT 70-10NS-45GR	23	12	11,5	18,5	38	50	16		
KRT 70-12NS-45GR	23	12	12,5	19,5	38	50	16		
KRT 95-8NS-45GR	28	13,5	8,5	17,5	38	50	18		
KRT 95-10NS-45GR	28	13,5	11,5	18,5	38	50	18		
KRT 95-12NS-45GR	28	13,5	12,5	19,5	38	50	18		
KRT 95-16NS-45GR	28	13,5	15,5	20,5	38	50	18		
KRT 120-10NS-45GR	29	15	11,5	18,5	41	25	19		
KRT 120-12NS-45GR	29	15	12,5	19,5	41	25	19		
KRT 120-16NS-45GR	29	15	15,5	20,5	41	25	19		

**Tube terminals 90° degrees 10 - 150 mm², KRF**

- Data: electrolytic copper, tin plated, cable inspection hole, for flexible and stranded, Cu-conductors.

Marking example KRF: 70 10F (Elpress logotype included)

70 = mm² 10 = palm hole for M10 F = type KRF, for flexible and stranded conductors



4

Cat. no. mm ² , Bolt	mm W	d	N	N ₁	A	Pcs/ pack	Die no.	Crimp tools page	
KR 10-6-90GR	13,0	5,0	6,5	11,5	15	100	8	9:3-6	9:8-30
KR 10-8-90GR	13,5	5,0	8,5	12,0	15	100	8		
KRF 16-6-90GR	13,0	6,0	6,5	11,5	17	100	9	↓	↓
KRF 16-8-90GR	13,5	6,0	8,5	12,0	17	100	9		
KRF 25-6-90GR	17,0	8,0	6,5	11,5	18,5	100	11		
KRF 25-8-90GR	17,0	8,0	8,5	12,0	18,5	100	11		
KRF 25-10-90GR	17,0	8,0	11,5	13,5	18,5	100	11		
KRF 35-6-90GR	18,0	9,0	6,5	11,5	22,5	100	13		
KRF 35-8-90GR	18,0	9,0	8,5	12,0	22,5	100	13		
KRF 35-10-90GR	18,0	9,0	11,5	13,5	22,5	100	13		
KRF 50-8-90GR	21	11,0	8,5	17,5	30,5	100	14,5		
KRF 50-10-90GR	21	11,0	11,5	18,5	30,5	100	14,5		
KRF 50-12-90GR	21	11,0	12,5	19,5	30,5	100	14,5		
KRF 70-8-90GR	25	13,0	8,5	17,5	31,5	50	17		
KRF 70-10-90GR	25	13,0	11,5	18,5	31,5	50	17		
KRF 70-12-90GR	25	13,0	12,5	19,5	31,5	50	17		
KRF 95-10-90GR	29	15,0	11,5	18,5	32,5	50	20		
KRF 95-12-90GR	29	15,0	12,5	19,5	32,5	50	20		
KRF 95-16-90GR	29	15,0	15,5	20,5	32,5	50	20		
KRF 120-10-90GR	32	17,0	11,5	18,5	34,5	25	22		
KRF 120-12-90GR	32	17,0	12,5	19,5	34,5	25	22		
KRF 120-16-90GR	32	17,0	15,5	20,5	34,5	25	22		
KRF 150-10-90GR	36	19,0	11,5	18,5	37,5	25	25		
KRF 150-12-90GR	36	19,0	12,5	19,5	37,5	25	25		
KRF 150-16-90GR	36	19,0	15,5	20,5	37,5	25	25		

System 1300 and 1400 can not crimp KR/KRF 10 - 35 mm², as the terminal necks are too short. Use V500, V611 or T2600 instead.



Tube terminals 90° degrees 10 - 120 mm², KRT

- Data: electrolytic copper, tin plated, for stranded, round, compressed Cu-conductors. KRT-types are without inspection hole (NS).

Marking example: 70 10 (Elpress logotype included)

70 = mm²

10 = palm hole for M10



Cat. no.	mm W	d	N	N ₁	A	Pcs/Pack	Die no.	Crimp tools page
KRT 10-6NS-90GR	13	4,5	6,5	11,5	15,5	100	7	9:3-6, 9:8-30
KRT 10-8NS-90GR	13,5	4,5	8,5	12	15,5	100	7	
KRT 16-6NS-90GR	13	5,4	6,5	11,5	16,5	100	8,5	
KRT 16-8NS-90GR	13,5	5,4	8,5	12	16,5	100	8,5	
KRT 16-10NS-90GR	16	5,4	11,5	13,5	17	100	8,5	
KRT 25-6NS-90GR	14	7	6,5	11,5	20	100	10	
KRT 25-8NS-90GR	14	7	8,5	12	20	100	10	
KRT 25-10NS-90GR	16	7	11,5	13,5	20	100	10	
KRT 35-6NS-90GR	17	8,5	6,5	11,5	23,5	100	12	
KRT 35-8NS-90GR	17	8,5	8,5	12	23,5	100	12	
KRT 35-10NS-90GR	19	8,5	11,5	13,5	23,5	100	12	
KRT 50-6NS-90GR	22	10	8,5	12	32,5	100	14	
KRT 50-8NS-90GR	20	10	11,5	17,5	31,5	100	14	
KRT 50-10NS-90GR	20	10	12,5	18,5	31,5	100	14	
KRT 70-8NS-90GR	23	12	8,5	17,5	32,5	50	16	
KRT 70-10NS-90GR	23	12	11,5	18,5	32,5	50	16	
KRT 70-12NS-90GR	23	12	12,5	19,5	32,5	50	16	
KRT 95-8NS-90GR	28	13,5	8,5	17,5	32,5	50	18	
KRT 95-10NS-90GR	28	13,5	11,5	18,5	32,5	50	18	
KRT 95-12NS-90GR	28	13,5	12,5	19,5	32,5	50	18	
KRT 95-16NS-90GR	28	13,5	15,5	20,5	32,5	50	18	
KRT 120-10NS-90GR	28	15	11,5	18,5	34,5	25	19	
KRT 120-12NS-90GR	28	15	12,5	19,5	34,5	25	19	
KRT 120-16NS-90GR	28	15	15,5	20,5	34,5	25	19	

4

System 1300 and 1400 can not crimp KR/KRF 10 - 35 mm², as the terminal necks are too short. Use V500, V611 or T2600 instead.



Tube terminals 10 - 300 mm² DIN 46235

■ Data: electrolytic copper, tin plated, dimensions according to DIN 46235, number of crimps marked on the neck of the terminal.

Palm marking example: 70 10

70 = mm²

10 = palm hole for M10



4

Cat. no. mm ² , bolt	mm W	d	L	Pcs/ pack	DIN die no.	Crimp tools page
KR 10-6 DIN	9,0	4,5	27	100	6	9:6, 9:10, 9:15, 9:20
KR 16-6 DIN	13,0	5,5	36	100	8	
KR 16-8 DIN	13,0	5,5	36	100	8	
KR 16-10 DIN	17,0	5,5	36	100	8	
KR 25-6 DIN	14,0	7,0	38	100	10	
KR 25-8 DIN	16,0	7,0	38	100	10	
KR 25-10 DIN	17,0	7,0	38	100	10	
KR 25-12 DIN	19,0	7,0	38	100	10	
KR 35-8 DIN	17,0	8,2	42	100	12	
KR 35-10 DIN	19,0	8,2	42	100	12	
KR 35-12 DIN	21	8,2	42	100	12	
KR 50-8 DIN	20	10,0	52	100	14	
KR 50-10 DIN	22	10,0	52	100	14	
KR 50-12 DIN	23	10,0	52	100	14	
KR 50-16 DIN	28	10,0	52	100	14	
KR 70-10 DIN	24	11,5	55	50	16	
KR 70-12 DIN	24	11,5	55	50	16	
KR 70-16 DIN	30	11,5	55	50	16	
KR 95-10 DIN	28	13,5	65	50	18	
KR 95-12 DIN	28	13,5	65	50	18	
KR 95-16 DIN	32	13,5	65	50	18	
KR 120-12 DIN	32	15,5	70	25	20	
KR 120-16 DIN	32	15,5	70	25	20	
KR 120-20 DIN	38	15,5	70	25	20	
KR 150-12 DIN	34	17,0	78	25	22	
KR 150-16 DIN	34	17,0	78	25	22	
KR 150-20 DIN	40	17,0	78	25	22	
KR 185-12 DIN	36	19,0	82	25	25	
KR 185-16 DIN	36	19,0	82	25	25	
KR 185-20 DIN	36	19,0	82	25	25	
KR 240-12 DIN	42	22	92	25	28	
KR 240-16 DIN	42	22	92	25	28	
KR 240-20 DIN	45	22	92	25	28	
KR 300-16 DIN	48	24	100	10	32	
KR 300-20 DIN	48	24	100	10	32	



Sheet metal terminals 10 - 240 mm² DIN 46234

■ Data: electrolytic copper, tin plated, dimensions according to DIN 46234.

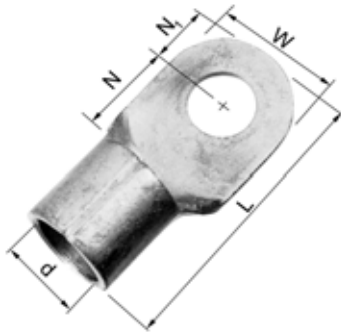

Cat. no. mm ² , bolt	mm W	d	N1	N	L	Pcs/ pack	Palm marking	Crimp tools page
B 10-5R	10,0	4,5	5,0	8,0	21	200	10	Please contact Elpress
B 10-6R	11,0	4,5	5,5	9,0	23	200	10	
B 10-8R	14,0	4,5	7,0	12,0	27	200	10	
B 10-10R	18,0	4,5	9,0	13,0	30	200	10	
B 10-12R	22	4,5	11,0	15,0	34	200	10	
B 16-5R	11,0	5,8	5,5	10,0	26	200	16	
B 16-6R	11,0	5,8	5,5	10,0	26	200	16	
B 16-8R	14,0	5,8	7,0	12,0	29	200	16	
B 16-10R	18,0	5,8	9,0	14,0	33	200	16	
B 16-12R	22	5,8	11,0	16,0	37	200	16	
B 25-5	12,0	7,5	6,0	14,0	31	200	25	
B 25-6R	12,0	7,5	6,0	14,0	31	200	25	
B 25-8R	16,0	7,5	8,0	14,0	33	200	25	
B 25-10R	18,0	7,5	9,0	15,0	35	200	25	
B 25-12R	22	7,5	11,0	20	42	200	25	
B 25-16R	28	7,5	14,0	24	49	200	25	
B 35-6R	15,0	9,0	7,5	14,0	34	200	35	
B 35-8R	16,0	9,0	8,0	14,0	34	200	35	
B 35-10R	18,0	9,0	9,0	15,0	36	200	35	
B 35-12R	22	9,0	11,0	19,0	42	200	35	
B 35-16R	28	9,0	14,0	24	50	200	35	
B 50-6R	18,0	11,0	9,0	18,0	43	100	50	
B 50-8R	18,0	11,0	9,0	18,0	43	100	50	
B 50-10R	18,0	11,0	9,0	18,0	43	100	50	
B 50-12R	22	11,0	11,0	20	47	100	50	
B 50-16R	28	11,0	14,0	24	54	100	50	
B 70-8R	22	13,0	11,0	20	49	100	70	
B 70-10R	22	13,0	11,0	20	49	100	70	
B 70-12R	22	13,0	11,0	20	49	100	70	
B 70-16R	28	13,0	14,0	24	56	100	70	
B 95-10R	24	15,0	12,0	22	54	100	95	
B 95-12R	24	15,0	12,0	22	54	100	95	
B 95-16R	28	15,0	14,0	24	58	100	95	
B 120-10R	24	16,5	12,0	22	56	50	120	
B 120-12R	24	16,5	12,0	22	56	50	120	
B 120-16R	28	16,5	14,0	26	62	50	120	
B 150-12R	30	19,0	15,0	26	65	50	150	
B 150-16R	30	19,0	15,0	26	65	50	150	
B 185-12R	36	21	18,0	22	74	50	185	
B 185-16R	36	21	18,0	22	74	50	185	
B 240-12R	38	24	19,0	24	75	50	240	
B 240-16R	38	24	19,0	24	75	50	240	



Terminals with narrow palm 35 - 240 mm²

■ Data: electrolytic copper, tin plated, for stranded conductors.

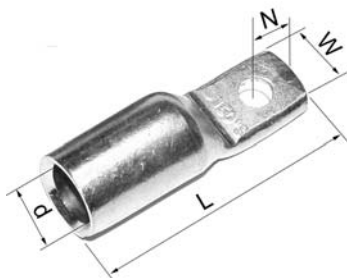

4

Cat. no.	mm W	d	N	L	Pcs/Pack	Die no.	Crimp tools page	
							9:3-6	9:8-30
KRTS 35-6	15	8,5	7,5	41	100	12	9:3-6	9:8-30
KRTS 50-6	15	10	7,5	45,5	25	14	↓	↓
KRTS 50-8	17	10	10	48	25	14		
KRTS 50-10	19	10	12	51,5	25	14		
KRTS 70-6	17	12	7,5	52,5	25	16		
KRTS 70-8	17	12	10	54	25	16		
KRTS 70-10	19	12	12	56,5	25	16		
KRTS 70-12	22	12	13	58	25	16		
KRTS 95-6	19	13,5	7,5	54,5	25	18		
KRTS 95-8	19	13,5	10	57	25	18		
KRTS 95-10	19	13,5	12	59	25	18		
KRTS 95-12	22	13,5	13	61	25	18		
KRTS 120-6	19	15	7,5	59,5	25	19		
KRTS 120-8	19	15	10	62	25	19		
KRTS 120-10	19	15	12	65	25	19		
KRTS 120-12	22	15	13	67	25	19		
KRTS 150-6	19	16,5	7,5	65,5	25	22		
KRTS 150-8	19	16,5	10	68	25	22		
KRTS 150-10	19	16,5	12	70	25	22		
KRTS 150-12	22	16,5	13	71,5	25	22		
KRTS 185-6	30	19	12	75	25	24		
KRTS 185-8	30	19	13	78	25	24		
KRTS 185-10	30	19	16	81	25	24		
KRTS 240-6	30	21	12	81	25	26		
KRTS 240-8	30	21	13	80	25	26		
KRTS 240-10	30	21	16	88	25	26		



Through connectors 0,75 - 800 mm², KS/KSF

- Data: electrolytic copper, tin plated, cable inspection hole and cable stop, for flexible and stranded Cu-conductors

Marking example: 20 95F 111 (earth-sign) Elpress logotype included

20 = die no. 95 = mm² F = type KSF, stranded and flexible conductors

111 = screen, mm²



Cat. no. mm ²	Screen cross section	mm d	D	L	Pcs/ pack	Crimp tools page
KS 0,75		1,3	2,8	14,0	100	8:9, 8:18-20
KS 1,5		1,8	3,3	14,0	100	9:3-6
KS 2,5		2,3	4,2	16,0	100	9:8-30
KS4		3,0	5,0	19,0	100	
KS6		4,0	6,0	19,0	100	
KS10		5,0	8,0	30	100	
KSF 16	15	6,0	9,0	35	100	
KSF 25	21-29	8,0	11,0	35	100	
KSF 35	41	9,0	13,0	35	100	
KSF 50	57	11,0	14,5	45	50	
KSF 70	72-88	13,0	17,0	45	50	
KSF 95	111	15,0	20	45	50	
KSF 120		17,0	22	55	50	
KSF 150		19,0	25	65	25	
KSF 185		21	27	70	25	
KSF 240A		22,5	29	70	25	9:13-15
KSF 300A		24	31,5	75	10	9:13-15
KSF 400A		30	38	100	10	9:23-30
KSF 500		33	42	135	5	9:23-30, 9:35-36
KSF 630		39	53	175		9:23-25
KSF 800		42	53	175		



Through connectors 16 - 800 mm², KSD/KST

- Data: electrolytic copper, tin plated, cable inspection hole and cable stop, for stranded, round, compressed Cu-conductors.

Marking example: 18 95 Elpress logotype included

18 = die no.

95 = mm²



4

Cat. no.	mm d	D	L	Pcs/Pack	Crimp tools page		
					9:3-6	9:8-30	
KSD 16	5,4	8	35	100	↓	↓	
KSD 25	6,7	9	30	100			
KSD 35	8	11	35	100			
KSD 50	9,5	12	40	50			
KSD 70	11,3	14	45	50			
KSD 95	13	16	55	50			
KSD 120	15	19	60	50	↓	↓	
KSD 150	17	22	65	50			
KSD 185	19	25	70	50			
KSD 240	21	27	70	50			
KSD 300	24	30	90	50			
KSD 400	26	32	90	25			
KSD 500	31	40	135	5	9:23-36	↓	
KSD 630	34	45	135	5	↓		
KSD 800	39	53	175	1	↓		
KST10	4,5	7	30	100	9:3-6		↓
KST 16	5,5	8,5	35	100	↓		
KST 25	7	10	40	100			
KST 35	8,5	12	45	100			
KST 50	10	14	50	50			
KST 70	12	16	55	50			
KST 95	13,5	18	60	50		↓	↓
KST 120	15	19	60	50			
KST 150	17	22	65	50			
KST 185	19	24	75	50			
KST 240	21	26	85	50			
KST 300	24	30	90	50			
KST 400	26	32	90	50	9:23-30	↓	
KST 500	31	40	135	5	9:23-30		
KST 630	34	45	135		9:23-25		
KST 800	39	53	175		9:35-36		



Through connectors with partition 10 - 400 mm²

- Data: electrolytic copper, tin plated, with partition to prevent oil-leakage, for flexible and stranded, Cu-conductors

Marking example: 20 95F 111 (earth-sign) Elpress logotype included

20 = die no. 95 = mm² F = type KSF, stranded and flexible conductors

111 = screen, mm²



Cat. no. mm ²	Screen cond. area	mm d	D	L	Pcs/ pack	Crimp tools page
KS 10M		5,0	8,0	36	100	9:3-6 9:8-30
KSF 16M	15	6,0	9,0	37	100	↓
KSF 25M	21-29	8,0	11,0	38	100	
KSF 35M	41	9,0	13,0	41	100	
KSF 50M	57	11,0	14,5	48	50	
KSF 70M	72-88	13,0	17,0	49	50	
KSF 95M	111	15,0	20	56	50	↓
KSF 120M		17,0	22	63	50	
KSF 150M		19,0	25	64	25	
KSF 185M		21	27	74	25	↓
KSF 240AM		22,5	29	76	25	
KSF 300AM		24,5	31,5	88	10	
KSF 400AM		30	38	105	10	

4

Parallel connectors for total cross section areas 0.5 - 7.5 mm²

- Data: electrolytic copper, tin plated.



mm ² Total	Cat. no.	mm d	D	L	Pcs/ pack	Marking	Crimp tools page
0,5-1,5	KS2x1P	1,6	3,2	7,0	100	-	8:9, 8:11
1,5-3,5	KS2x2,5P	2,3	3,9	2,3	100	-	8:9, 8:11
4-7,5	KS2x6P	3,6	5,6	3,6	100	-	8:11

Connectors for solid Cu conductors 6 - 16 mm²

- Data: electrolytic copper, for solid conductors (to IEC 60228 class 1).



mm ²	Cat. no.	mm d	D	L	Pcs/ pack	Marking*	Crimp tools page
6	CUT 6	3,0	5,0	27	100	CUT6	9:3
10	CUT 10	4,0	6,0	27	100	CUT10	↓
10	KS10CUT10**	5,0/4,0	8,0/6,0	32	100	KS10CUT10	
16	CUT 16	5,0	8,0	35	100	CUT16	

* Elpress logotype included in marking. ** Tin plated



Pin terminals 10 - 95 mm² DIN 46230

■ Data: electrolytic copper, tin plated, dimensions according to DIN 46230.



mm ²	Cat. no.	mm W	L ₁	L	Inner Ø d	Pcs/ pack	Crimp tools page
10	B10SR	4,3	12,0	22	4,5	100	9:3-6, 9:8-30
16	B16SR	5,5	13,0	26	5,8	100	↓
25	B25SR	6,8	15,0	34	7,0	100	
35	B35SR	8,0	20	41	8,7	100	
50	B50SR	9,5	20	45	9,8	100	
70	B70SR	11,0	23	55	11,5	100	
95	B95SR		23	55	13,8	100	

4

Through connectors for road lighting cables 6 - 16 mm² - SYSTEM 0616

■ Data: electrolytic copper, tin plated, for solid and stranded conductors, included in SYSTEM 0616 for road lighting, see chapter 9.

■ Crimp tool, see page 9:4.

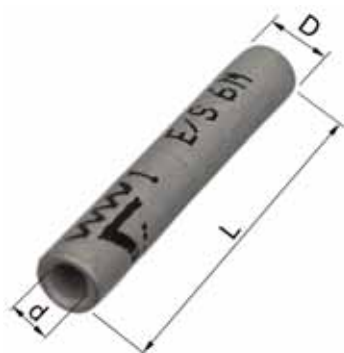

mm ²	Cat. no.	mm d	D	L	Pcs/ pack	Marking*
6	KSE/S6M	3,5	5,7	35	100	I E/S6M
6-10	KSE/S6- KSE/S10	3,5-4,5	5,7-7,0	35	100	II E/S10 I E/S6
10	KSE/S10	4,5	7,0	35	100	II E/S10
10	KSE/S10M	4,5	7,0	35	100	II E/S10M
10-16	KSE/S10- KSE/S16	4,5-5,5	7,0-8,5	40	100	III E/S16 II E/S10
16	KSE/S16	5,5	8,5	40	100	III E/S16
16	KSE/S16M	5,5	8,5	40	100	III E/S16M

* Elpress logotype included in marking.

** I, II and III refers to die nests in dies MED616 to be used, see page 9:4.

Tube terminals for Ericsson Cables Excel type 10 - 16 mm²

■ Data: electrolytic copper, tin plated, for PEX-insulated cables 10 and 16 mm² Cu solid (Ericsson Excel type), to be applied non-tensioned.



Cat. no. mm ² , bolt	mm W	d	N	N ₁	L	Pcs/ pack	Crimp die id-no.	Crimp tools page
KRX 10-8	22	4,5	8,5	17,5	68	24	7	9:6
KRX 10-10	22	4,5	11,5	18,5	72	24	7	↓
KRX 10-12	22	4,5	12,5	19,5	74	24	7	

Two crimps are made when using the V500-, V611-, PV611- or T2600-systems, die TB7-20.

Connectors for Ericsson Cables Excel type 10 - 16 mm²

■ Data: electrolytic copper, tin plated, for PEX-insulated cables 100 mm² Cu solid (Excel), to be applied non-tensioned.



Cat. no. mm ²	mm d	D	L	Pcs/ pack	Marking*	Crimp tool page
KSX 10	4,5	7,0	65	24	10X 7	9:6

* Elpress logotype included.

Two plus two crimps are made when using the V500-, V611-, PV611-, or T2600-Systems, die TB7-20.



Branch connectors (C-sleeves) 6 - 300 mm²

- Data: electrolytic copper, for connecting and branching of earth conductors, in some cases two adjacent compressions are necessary, see tools chapter 9.

Elpress logotype is included in the marking. On the "reverse side" the C-sleeve is marked with the applicable wire area ranges.

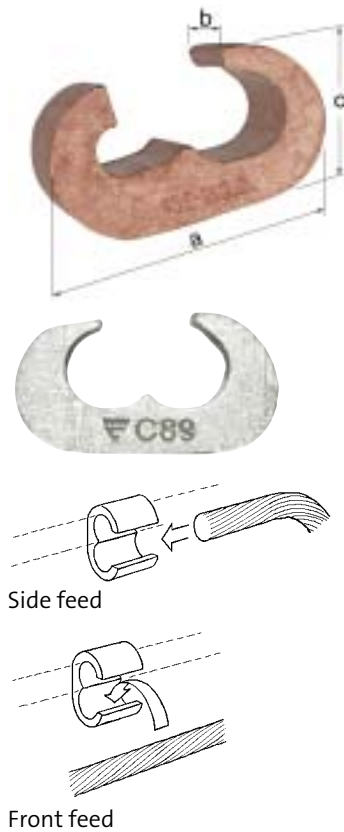

Cat. no.	Wire section area ranges		mm a	b	c	Pcs/pack	Die id-no.
	Side feed	Front feed					
C4	10-6/10-6	10/6	13,0	12,0	8,0	100	4
C5	16-10/16-10	10/16-10	16,0	15,0	10,0	100	5
C6	25-16/25-16 25/10	16/25-16	22	16,0	12,0	100	6
C89	25-50/25-50 16-50/35-50	25-50/25-35 16-50/35	30	18	16/ 15,4	50	8-9
C11-8	70-50/35-25	50/30-25	31	23	19,0	50	11
C11-9	70-50/50-35	50/50-35	31	23	19,0	50	11
C11	70-50/70-50	50/70-50	31	24	19,0	50	11
C13-8	95-70/35-25	70/35-25	35	25	22	50	13
C13-9	95-70/50-35	70/50-35	35	25	22	50	13
C13-11	95-70/70-50	70/70-50	35	25	22	50	13
C13	95-70/95-70	70/95-70	35	25	22	50	13
C15-8	120-95/35-25	95/35-25	41	30	26	25	15
C15-9	120-95/50-35	95/50-35	41	30	26	25	15
C15-11	120-95/70-50	95/70-50	41	30	26	25	15
C15-13	120-95/95-70	95/95-70	41	30	26	25	15
C15	120-95/120-95	95/95	41	30	26	25	15
C16-9	150-120/50-35	150-120/50-35	53	35	30	10	16
C16-13	150-120/95-70	150-120/95-70	53	35	30	10	16
C16	150-120/150-120	150-120/150-120	53	35	30	10	16
C18-8	185-150/35	185-150/35	55	40	34	10	18
C18-9	185-150/50	185-150/50	55	40	34	10	18
C18-11	185-150/70	185-150/70	55	40	34	10	18
C18-13	185-150/95	185-150/95	55	40	34	10	18
C18-15	185-150/120	185-150/120	55	40	34	10	18
C18-16	185-150/150	185-150/150	55	40	34	10	18
C18	185/185	185/185	60	40	34	10	18
C21-8	240/35	240/35	55	40	34	10	18
C21-9	240/50	240/50	55	40	34	10	18
C21-11	240/70	240/70	55	40	34	10	18
C21-13	240/95	240/95	55	40	34	10	18
C21-15	240/120	240/120	55	40	34	10	18
C21-16	240/150	240/150	55	41	34	10	18
C21-18	240/185	240/185	70	40	40	10	21
C21	240/240	240/240	70	40	40	10	21
C23-16	300/150-120	300/150-120	70	40	40	10	21
C23	300/300	300/300	70	40	40	10	21



Application table for C-sleeves (side feed only)

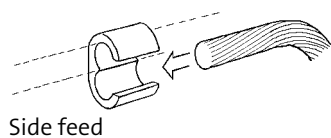

Side feed

Through conductor, mm ²	Branch conductor, mm ²					
	6	10	16	25	35	50
6	C4	C4				
10	C4	C4/C5	C5			
16		C5	C6	C6		
25		C6	C6	C6/C89	C89	
35			C89	C89	C89	C89
50			C89	C89	C89	C89
50				C11-8	C11-8/C11-9	C11-9/C11
70				C11-8	C118/C11-9	C11-9/C11
70				C13-8	C13-8	C13-11
95						C13-11
95				C15-8	C15-8/C15-9	C15-9/C15-11
120				C15-8	C15-8/C15-9	C15-9/C15-11
120						C16-9
150					C16-9	C16-9
150						C18-9
185					C18-8	C18-9
240					C21-8	C21-9
300						

Through conductor mm ²	Branch conductor, mm ²						
	70	95	120	150	185	240	300
6							
10							
16							
25							
35							
35							
50							
50	C11						
70	C11						
70	C13-11/C13	C13					
95	C13-11/C13	C13					
95	C15-11/C15-13	C15-3/C15	C15				
120	C15-11/C15-13	C15-13/C15	C15				
120	C16-13	C16-13	C16	C16			
150	C16-13	C16-13	C16	C16			
150	C18-11	C18-13	C18-15	C18-16			
185	C18-11	C18-13	C18-15	C18-16	C18		
240	C21-11	C21-13	C21-15	C21-16	C21-18	C21	
300				C23-16			C23

Note

- Open choice is marked with slash "/"
- When choosing between e.g. C11-9 and C11, use primarily C11
- The smaller sleeve is preferred, e.g. C8 in stead of C9, etc.

